

Sodium Cyanide Safety Handling Guide



2012

TAEKWANG Industrial Co., Ltd.
Petrochemical Department

CONTENT

1. Introduction ; TAEKWANG INDUSTRIAL
2. Petrochemical Plant
3. Why Taekwang NaCN ?
4. Production process & Specification
5. Packing
6. Unpacking
7. Personal Protective Equipment
8. Handling, Transportation & Storage
9. First Aid Measures
10. Antidote
11. How to Wear Gas Mask for Hydrogen Cyanide
12. How to Use HCN Gas Detector
13. FAQ

1. TAEKWANG INDUSTRIAL

Taekwang is recognized as a Global company in the field Of the Petrochemical and Synthetic Fiber industrial.

- ▶ Location : Head Office (Seoul in Korea)
Plant (Petrochemical Complex of Ulsan city in Korea)
- ▶ Established in 1950year
- ▶ 1,000 employees
- ▶ Products : Petrochemical – PTA, Propylene, AN, ACN, AMS, NaCN etc.,
Synthetic Fiber – Polyester, Acrylic, Spandex, Nylon etc.,

2. Petrochemical Plant

Plant	Production Item	Capacity (MT/yr)	Application
#1	Purified Terephthalic Acid	1,000,000	Raw material of polyester fiber and PET-bottle
#2	Propylene	250,000	Raw material of polypropylene, acrylonitrile, etc
#3	Acrylonitrile	250,000	Raw material of acrylic fibers, ABS/SAN synthetic resin, etc
	Sodium Cyanide	67,000	Extraction of gold and Silver from ores, Electroplating etc
	Acetonitrile	800	Solvent in the production of pharmaceuticals, and fine chemicals, etc
	Ammonium Sulfate	55,000	Raw material of mixed and complexes fertilizers

2-1) Petrochemical Plant (PTA)



2-2) Petrochemical Plant (Propylene)



2-3) Petrochemical Plant (AN,ACN,AMS,NaCN)



3-1) Why Taekwang NaCN ?

1) Main NaCN Manufacturer

	Name	Country	Annual Production
1	Dupont	USA	100,000mt
2	Orica	Australia	80,000mt
3	Taekwang	Korea	65,000mt
4	AGR	Australia	60,000mt
5	Cyplus	Germany	60,000mt

2) Major Gold Producer

	Name	Region	Main Supplier
1	Barrick	N.America S.America	
2	Newmont	Australia S.America	
3	Anglogold Ashanti	Africa Australia	Taekwang
4	Goldfields	Africa Australia	Taekwang
5	Kinross	N.America S.America	

► As a No.3 Manufacturer, Now we are supplying to Major gold Mining corp.

3-2) Why Taekwang NaCN ?



3-3) Why Taekwang NaCN ?

- ▶ Fulfillment of Global standard's Qualification & Safety process
: ISO 9001-2000, ICMC



- ▶ International Cyanide Management Code URL address;
(<http://www.cyanidecode.org>
/signatory_producer_taekwang.php)

4-1) Production Process & Specification

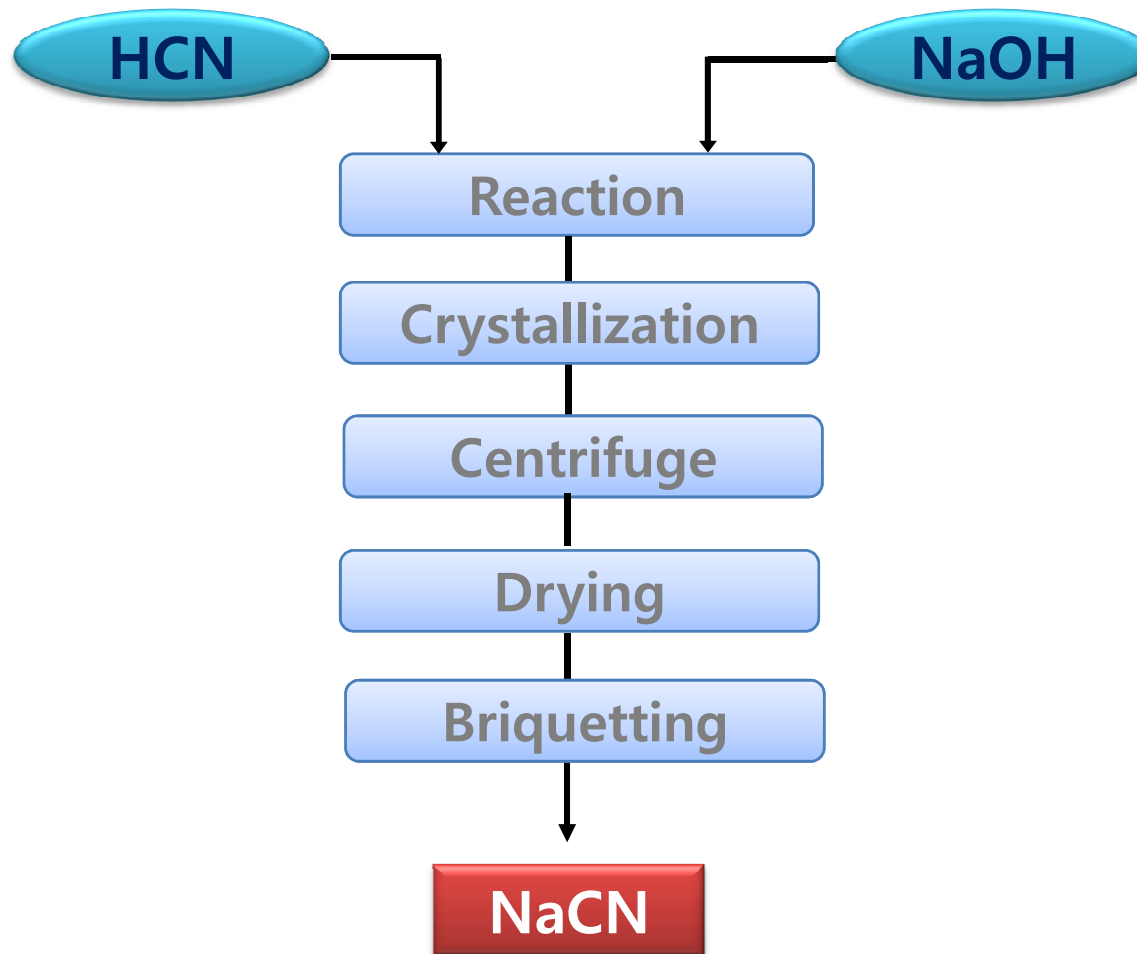

4-2) Production Process & Specification

1.Specification

	Unit	Specification	Remark
Purity	%	98.0 Min.	
NaOH	%	0.5 Max.	
Na ₂ CO ₃	%	1.0 Max.	
H ₂ O	%	0.5 Max.	

2.Shape



- Weight :
Approximate 14grams/1 Briquette
- Dimension
(Length x Width x Thickness) =
33mm x 30mm x 18mm

5. Packing

1. Drum Packing



2. Box Packing



6. Unpacking

1. Drum Unpacking



2. Box Unpacking

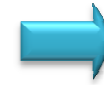

7. Personal Protective Equipment

- NaCN and HCN Gas : Toxic Chemical
- Personal Protective Equipment as following must be kept in the safety box near the place handling NaCN and must be put on when handling.
- Personal Protective Equipment



Gas Mask



Face Shield



Safety Goggles



Rubber Glovers



Chemical Resistant
Clothing



Rubber Boots

8-1) Handling, Transportation & Storage

1.Handling

- 1) Put on rubber gloves, aprons, boots, goggles and other protective items when handling NaCN
- 2) Wear gas mask when handling NaCN.
- 3) Do not handle the material near places where acids is handled.
 - HCN Gas is generated if NaCN is reacted with Acid.
 - HCN Gas is deadly toxic and poisonous.
- 4) This material should be handled at least two workers to watch the situation in buddy system.
- 5) Do not eat food or drinks in the same area
- 6) The workers must take shower and change their clothe after work.

8-2) Handling, Transportation & Storage

2. Transportation



Dangerous Sticker



Preparation



Break Time



Under Speed Limit



Buddy System



Emergency call

8-3) Handling, Transportation & Storage

3.Storage



No direct sunlight



Storage Sealed



Ventilation



Stacking

9. First Aid Measures

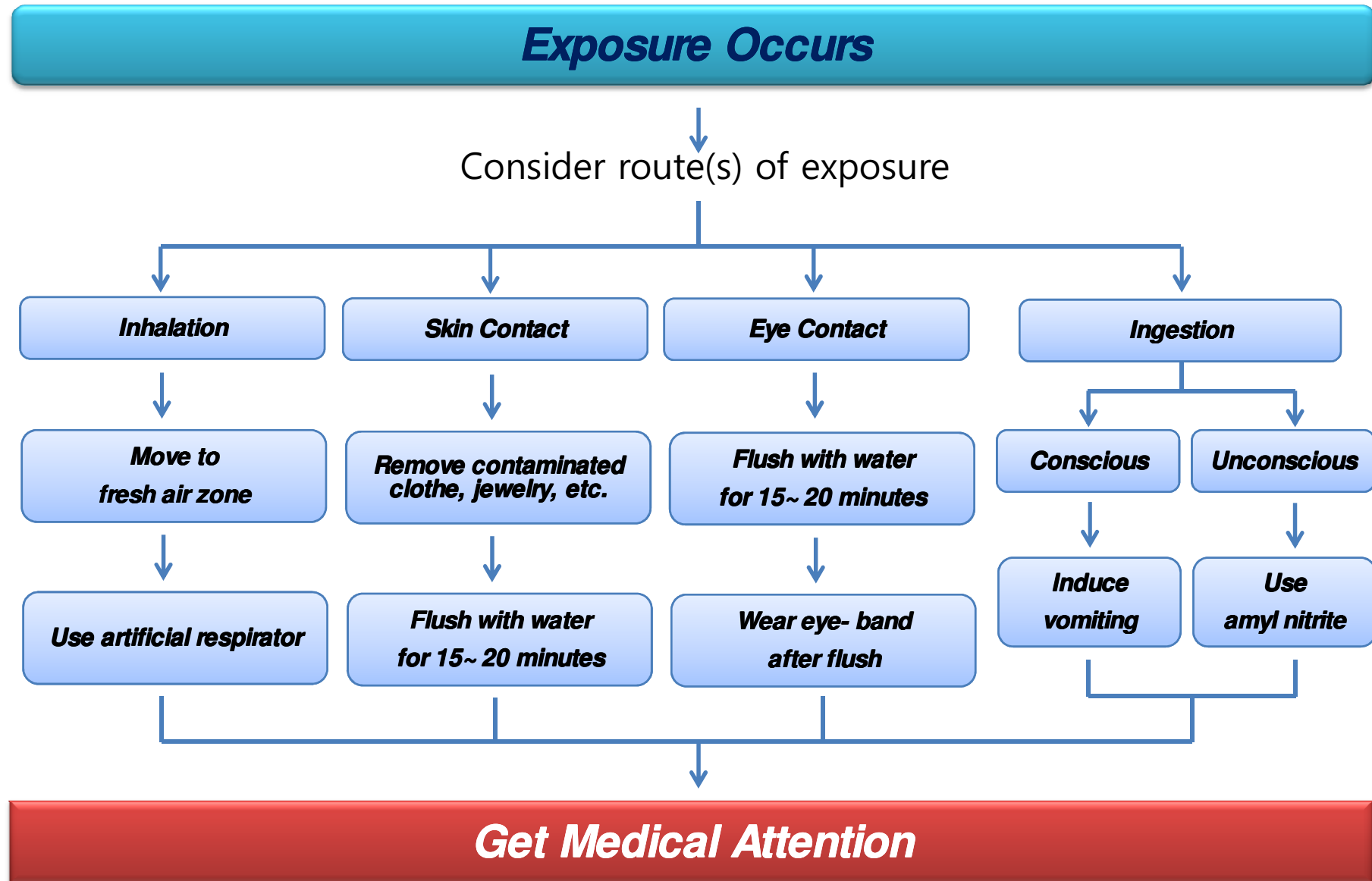

10. Antidote



Antidote Box



Amyl nitrite



Sodium nitrite

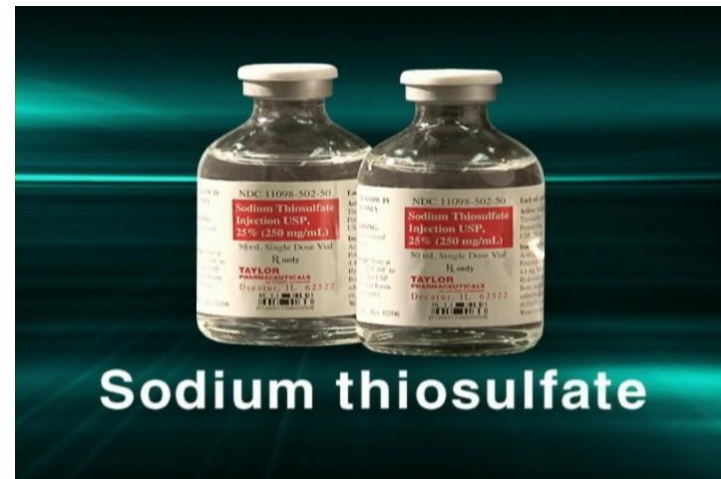

Sodium thiosulfate

10. Antidote



1. When the patient is conscious

If the patient is conscious, place the broken amyl nitrite ampule under the patient's nose five times at intervals of 15 seconds. If necessary, change the ampule with a new one every five minutes. It is possible that three to four ampule may need to be used

10. Antidote



2. In case of swallowing

In the case of swallowing sodium cyanide, it is necessary to induce vomiting in the patient through the use of an emetic such as one percent sodium thiosulfate or soapy water

10. Antidote

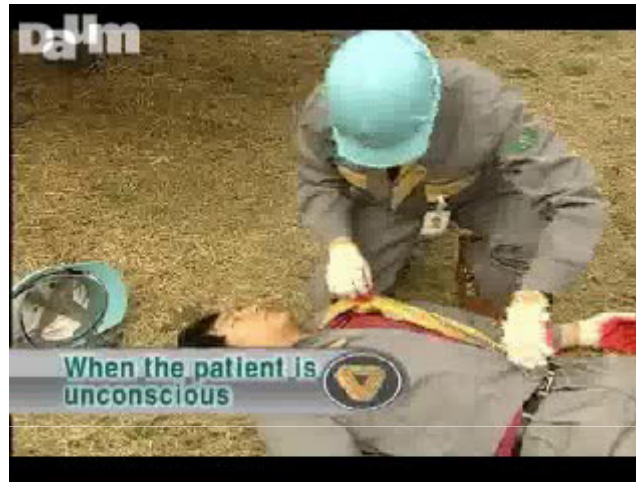

3. When the patient is unconscious

Never give anything by mouth to an unconscious patient. Place the broken ampule of amyl nitrite under the patient's nose five times at intervals of 15 seconds. Have the patient inhale oxygen if he shows no progress toward recovery. It is possible to give inhalations of oxygen to a patient at 15 second intervals following the placement of amyl nitrite on the inside edge of the resuscitator. If necessary, change the ampule with a new one every three minutes. It is possible that three to four ampules may be needed.

10. Antidote



4. When breathing has stopped

If breathing has stopped artificial respiration must be administered until the patient begins to breathe. When the patient begins to breathe, the first aid to be administered should be amyl nitrite.

11. How to Wear Gas Mask for Hydrogen Cyanide



12. How to use HCN Gas Detector



13. FAQ (Frequently Asked Question)

1. Which material is used for tank and piping for liquid NaCN?

→ If the Liquid NaCN temperature is higher than 38°C, NaCN and water could react and effect HCN gas then the piping and the tank could be damaged. Usually Tank and Piping material is made of 304 stainless steel or 316 stainless steel however the velocity is under 1.2~1.5m/sec, carbon steel could be used.

※ To prevent temperature increase, Liquid NaCN tank needs to install cooling coil and outside insulation.

2. Why shouldn't workers eat food or drinks in the place where NaCN is stored or handled?

→ NaCN dust can exist in the area. If NaCN dust may react with water in your food or drinks, HCN gas can generate.

3. Why should pH be high, when solid NaCN is used in water solution?

→ HCN gas can be released from cyanide solution if the pH is not kept high. Therefore, We recommend to keep a minimum pH of 12 to keep HCN at a low level.

4. Why should you store NaCN in a warehouse where there is no direct sunlight and temperature needs to be cool and dry?

→ If a solid NaCN contacts with direct sunlight, it can decompose and generate HCN gas. Higher temperature can cause more HCN gas. Therefore, we recommend that a warehouse should have no direct sunlight, cool and dry place.

13. FAQ (Frequently Asked Question)

5. What are cautions when opening NaCN drum?

→ NaCN may react with water in existed air in the drum, then HCN and NH₃ gas may generate. Therefore, we recommend you should wear gas mask when you open NaCN drum. However, when you open NaCN drum, you should work opposite side where the air blows, then you may wear dust mask.

6. What should you prevent from leaving leftover NaCN?

→ NaCN leftover should be sealed completely, so that the leftover can not interact with water in the air; to prevent HCN gas.

7. Why should a warehouse be well-ventilated?

→ During NaCN is stored, NaCN may react with water in air, and HCN and NH₃ gas may generate. HCN and NH₃ gas are lighter than air, so they are blow off naturally. However, if there are no ventilation system in a warehouse, HCN and NH₃ gas can remain in a warehouse partially. Therefore, to remove HCN and NH₃ gas in a warehouse completely, ventilation system is necessary.

8. How much is Antidote Kit and how do you get it?

→ One kit is about \$400. You can get this kit from Akorn Pharmaceuticals. (www.akorn.com)

13. FAQ (Frequently Asked Question)

9. How do you know whether there is HCN gas leakage when you use HCN gas detector?

→ If there is HCN gas leakage, the detector will indicate red color shown as below. First tube is non-detected, second one is 20ppm HCN gas and last one is 60ppm HCN gas.



10. What do you have to do when there is HCN from leftover NaCN in storage without HCN gas detector?

→ You have to install ventilation system in your warehouse. If you don't have ventilation system, you have to blow off the gas in the warehouse. If you feel ammonia or some other strange odor, you should move to a safe area immediately.

13. FAQ (Frequently Asked Question)

11. Using Taekwang's Box, NaCN product is well packed up with PP woven bag and PE bag so that, it is 0% that Box would get in contact with NaCN.

In this case, can I use the box in another use or do I need to burn and get rid of it?

In Indonesian regulation, packing material needs to be incinerated but it doesn't have any regulation for boxes.

→ Just in case, if there any NaCN leftover in the box, NaCN has any contact with the body then, accident can occur so it is better to use a professional company to get rid of the box. But also it is to prevent the environmental pollution.

→ Even though NaCN package is incinerated at a degree of 1496°C the left over could still remain. So it is better to use a professional disposal handling company.

13. FAQ (Frequently Asked Question)

12. In a new mining area, storage is under construction so individually purchasing their own container and store the NaCN and lock it. In this case, they run the ventilation system 1 time/day. How long can NaCN be stored for maximum with this storage system? I heard that Taekwang export a lot of amount to Africa, then is there any problem keeping in the container for 2~3 month?

1) It is desirable that you keep it in a cool storage area with well ventilated place.

2) If storing the container which has NaCN products in the container,

- If container which has NaCN products is being exposed in direct sunlight,

The container temperature would rise due to the radiant heat

→ Box temperature rise → NaCN temperature rise → HCN gas could occur

→ HCN gas could exist in container

→ Somebody might get hurt when opening the container

- If the container which has NaCN products is being exposed to rain,

H₂O could inflow into the inner container → inflow into the box

→ inflow into the PE package → NaCN + HCN can react → HCN gas could occur

→ HCN gas could exist in container

→ Somebody might get hurt when opening the container

Due to the above answer, storing NaCN box in container is not desirable.

13. FAQ (Frequently Asked Question)

14. Taekwang's demanding of personal protective equipment, could you explain the gas mask filter's specification? Does it need to be HCN gas mask filter or not?

→1) Need to use the certified NIOSH (USA) filter for Gas Mask.

2) Surely, need to use HCN gas filter.

15. How long would the purity of NaCN maintain in the beaker in the laboratory?

→ NaCN product have high deliquescence,

so If you leave the NaCN in the beaker in the air,

NaCN can react with $H_2O \rightarrow HCN$ gas could occur → Somebody might get hurt

→ We don't leave the NaCN by itself in the atmosphere.

→ There is no data of maintaining the purity

13. FAQ (Frequently Asked Question)

16. What is the exact expiry of NaCN?

As Taekwang mentioned, if we store our products at a cool or dry storage, is there no problem that we could keep the product for 1 year?

→ The expiry of NaCN is depend on the condition of storage such as temperature and humidity. If you store NaCN in a cool and dry place, you can store NaCN for 1 year.

17. What do I have to do when there is HCN from leftover NaCN in storage without HCN gas detector?

→ You have to install ventilation system in your warehouse. If you don't have ventilation system, you have to blow off the gas in the warehouse. If you feel ammonia or some other strange odor, you should move to a safe area immediately.

13. FAQ (Frequently Asked Question)

19. They would like to know how to treat waste water. (Taekwang Standard)

For the moment, inform them we use water with Hydrochloric acid in order to dilute NaCN under 1ppm and then release it They would like to know how to handle disposal process. Malaysian country regulation is 0.5ppm

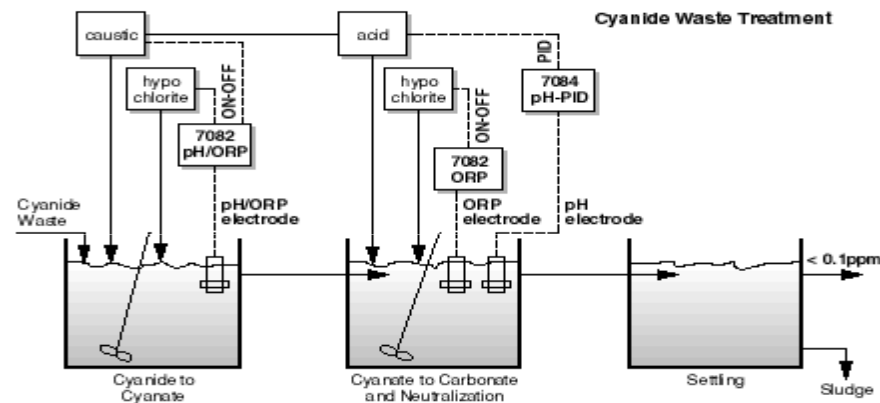
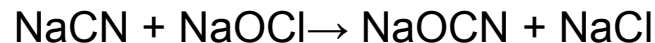

figure 1

1) 1st Step



- Operation Condition : pH 10.5 ~ 1.1, ORP 300~350 mV

2) 2nd Step

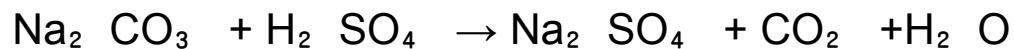

- Operation Condition : pH 7.5~ 8.0, ORP 600~650 mV

13. FAQ (Frequently Asked Question)

Throughout the NaCN's process which is mentioned above, NaCN is separated from Effluent Water by NaOCl discharge CO_2 / N_2 to the atmosphere, sedimenting Na_2SO_4 and then exhaustion of CN concentration will be below 1ppm

3) Among Effluent water, in order to keep CN concentration below 1ppm

NaOH/NaOCl Consumption Rate

- NaOH Consumption Rate : 0.82 kg-NaOH/kg NaCN

- NaOCl Consumption Rate : 3.80 kg-NaOCl/kg NaCN



STORAGE CONDITION



STORAGE CONDITION



CAUTION LABEL



CAUTION LABEL



MANUFACTURER



MANUFACTURER



NET WEIGHT & ORIGIN



NET WEIGHT & ORIGIN



COLOR:WHITE



COLOR:WHITE



TYPE:BRIQUETTE



TYPE:BRIQUETTE



SEALING



DOOR CLOSE



EMPTY CONTAINER



HALF STUFFING



FULL STUFFING



CONTAINER NUMBER

Q & A

Thank You !